

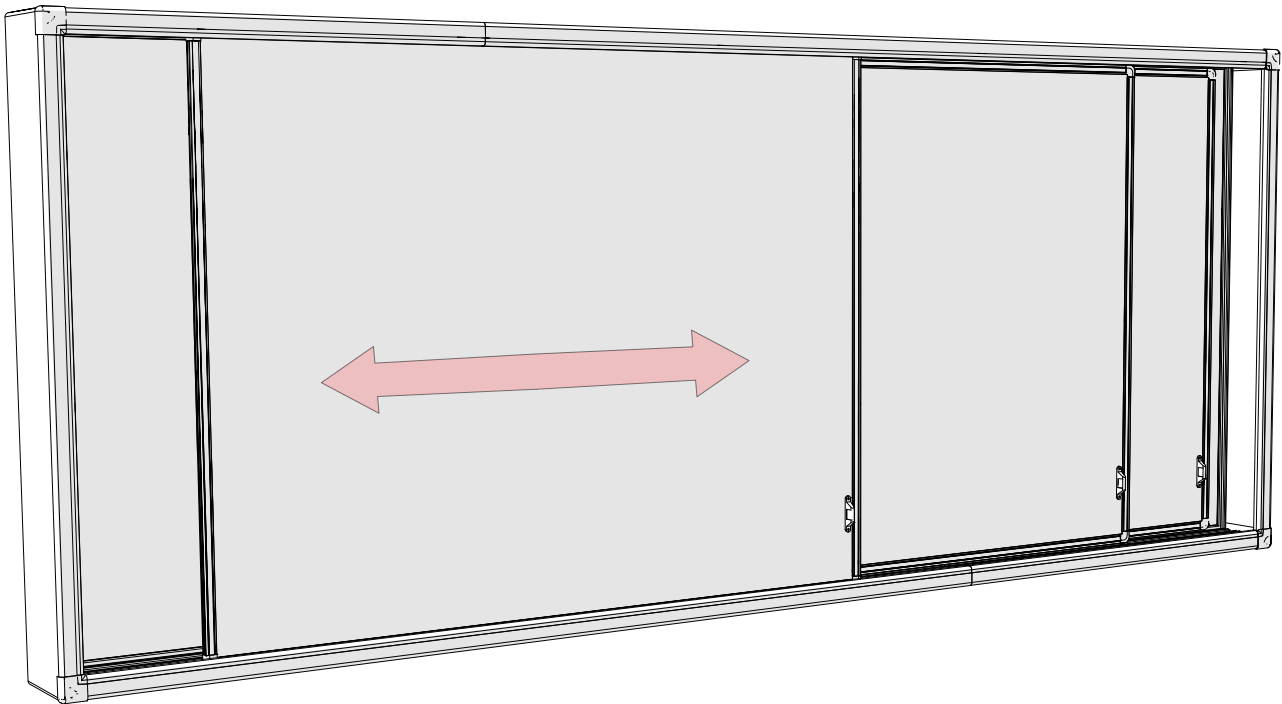

LEARNING  
SURFACES

# Horizontal Slider

Assembly & Installation



# Step 1

Connect the rails with the pre-installed plates to a end cap.

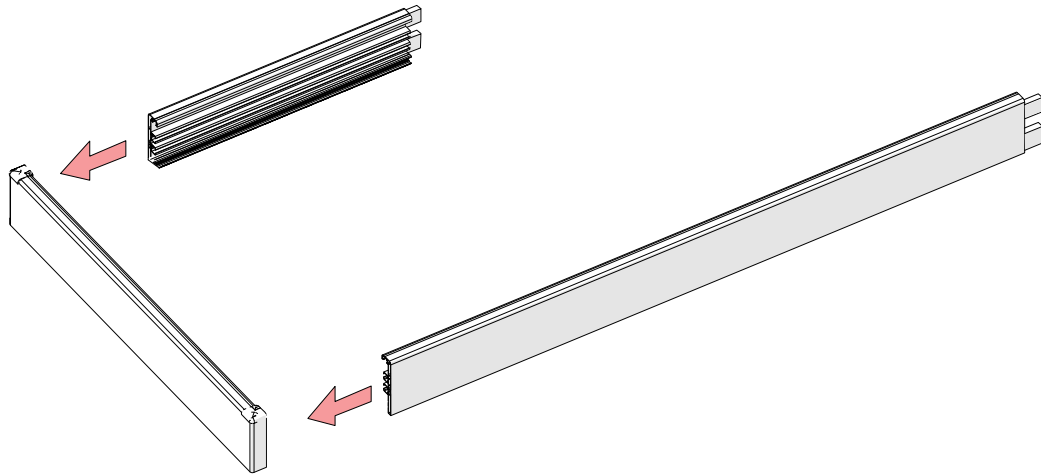

# Step 2

Take the remaining two rails and connect to the plates. Remember to keep rivet holes facing the inside.

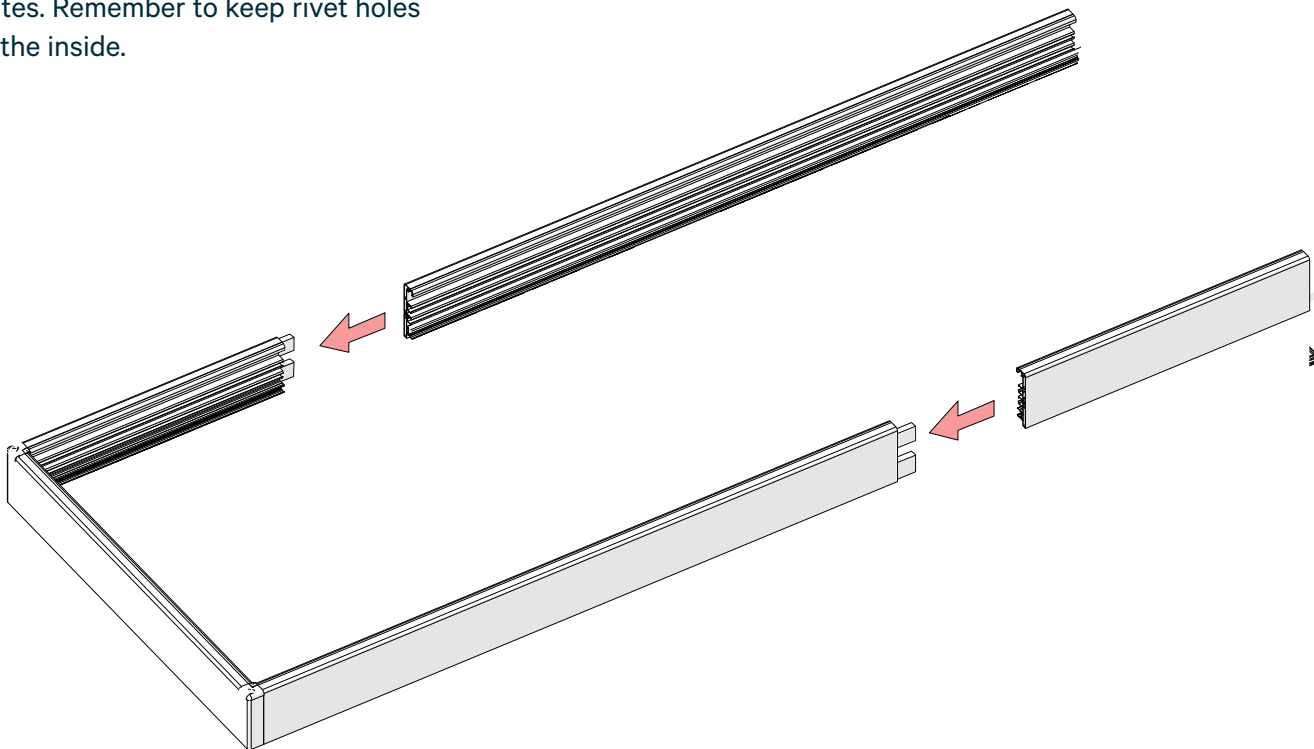

## Step 3

Rivet the remaining holes to secure frame.

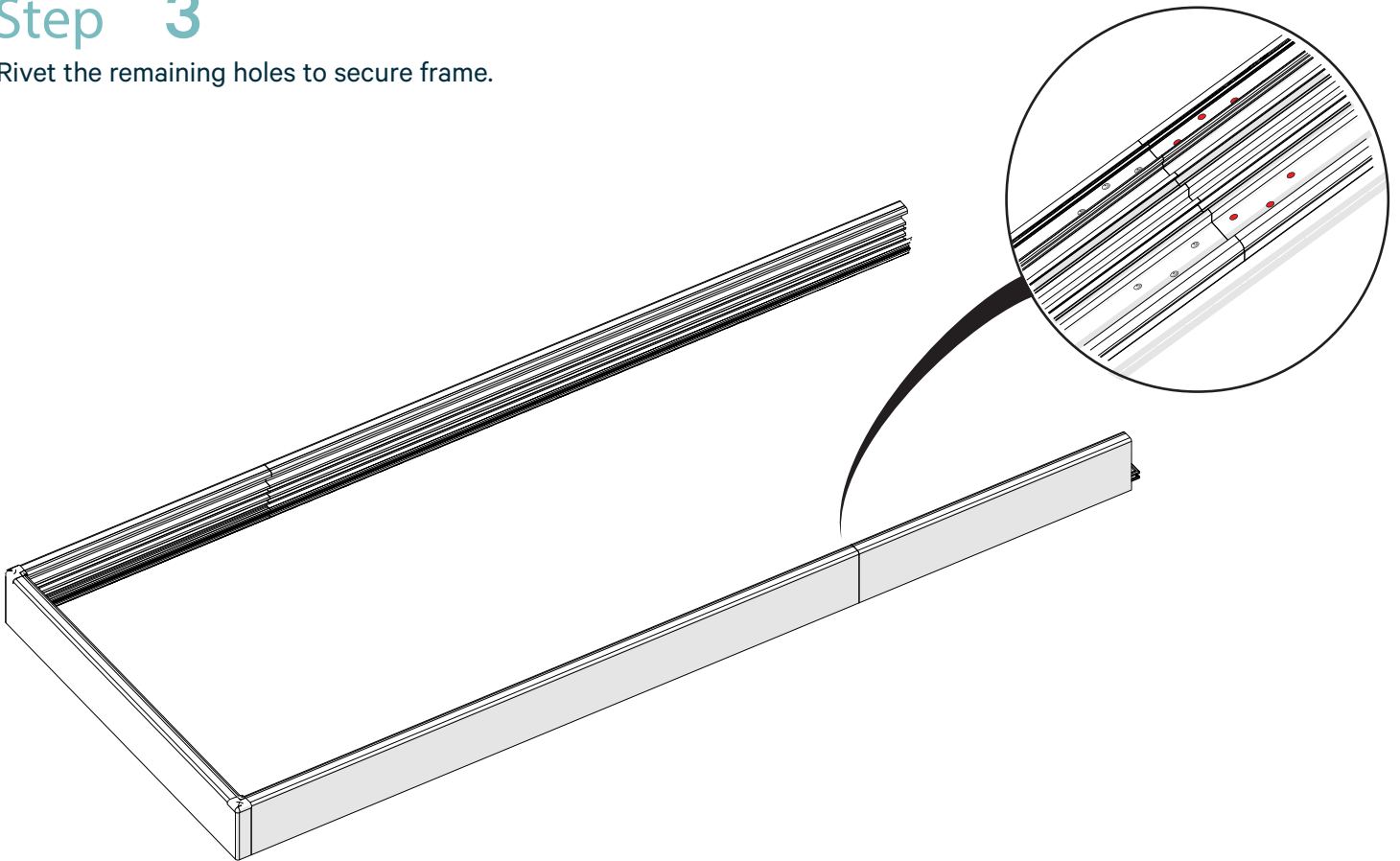

## Step 4

Slide the first backboard through the channel.  
The “I” molding should face towards the center.

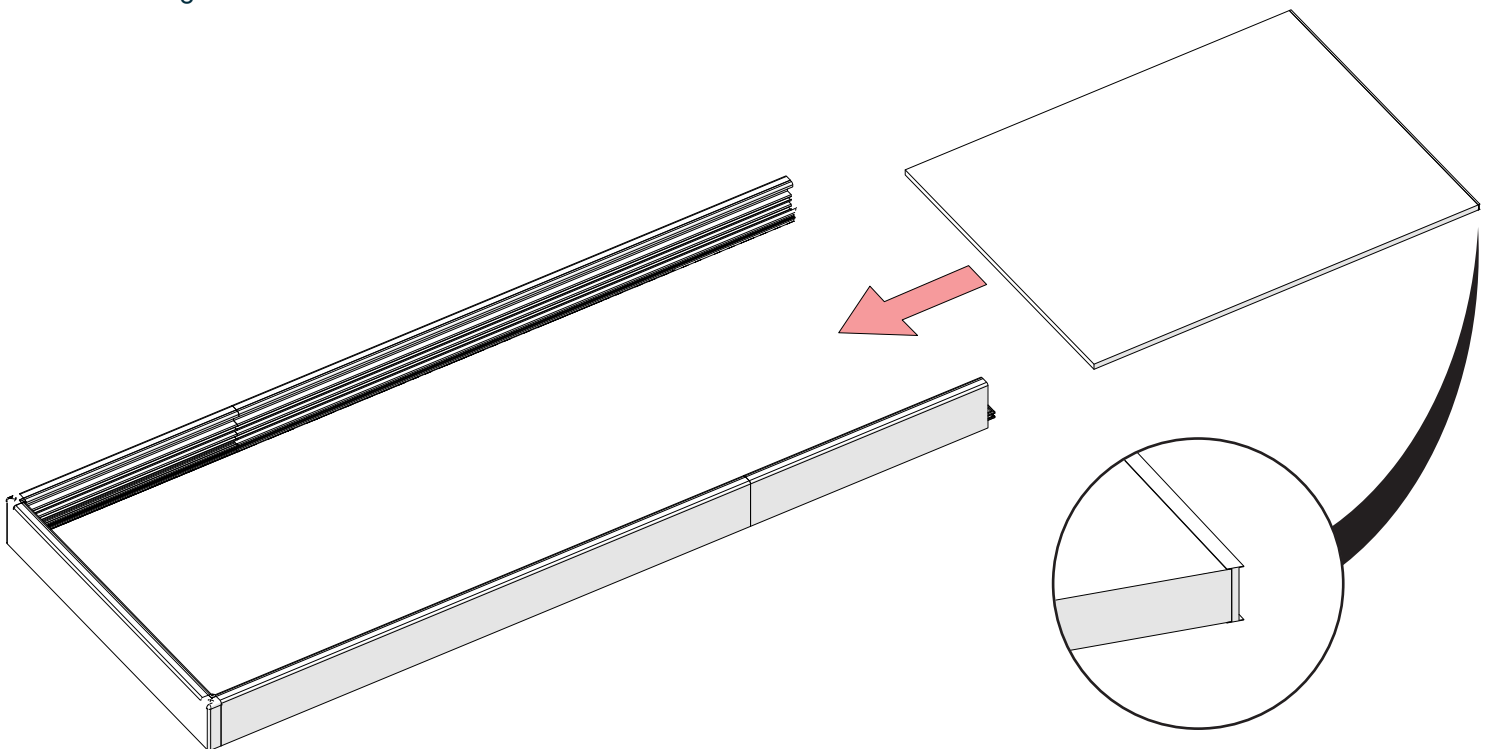

## Step 5

Slide the second board through the channel.  
The inside will fit into the “I” molding.

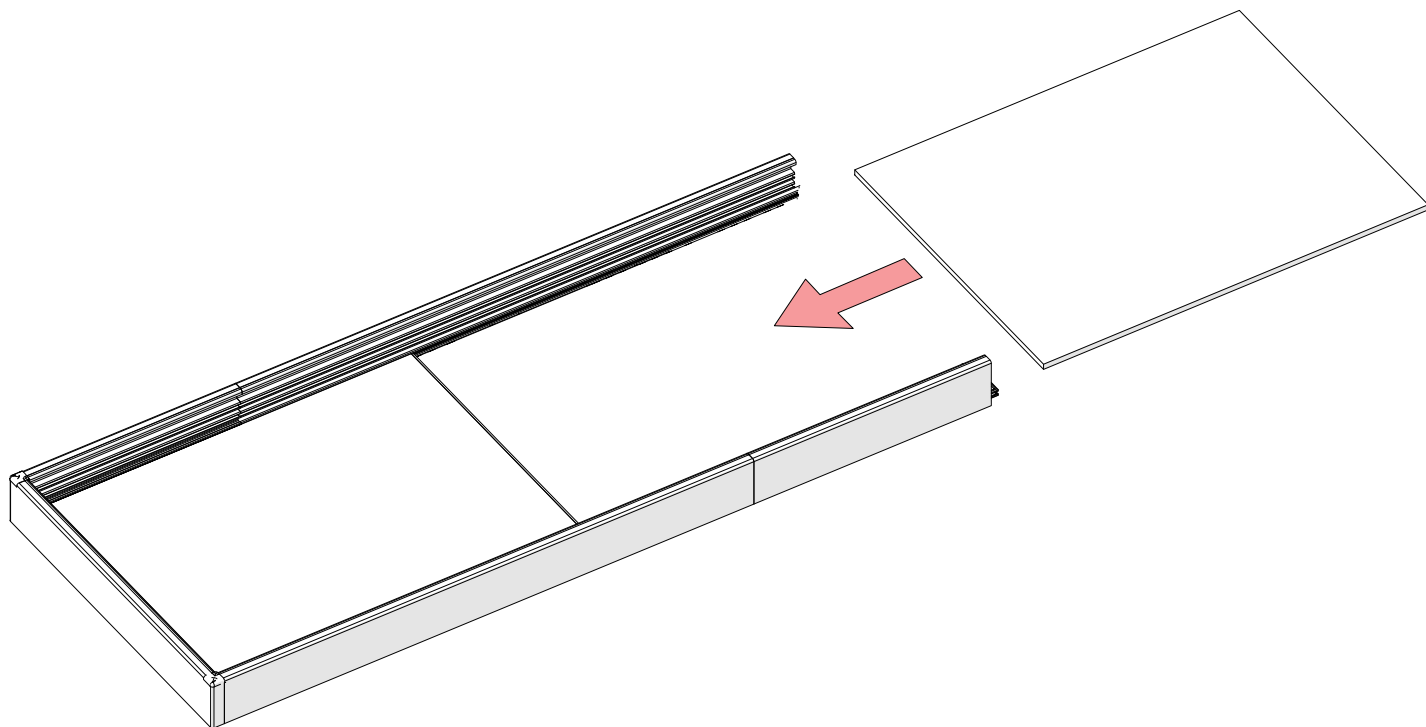

## Step 6

Insert the sliders into the rails. For configurations with more than one slider the tallest slider will go on top.

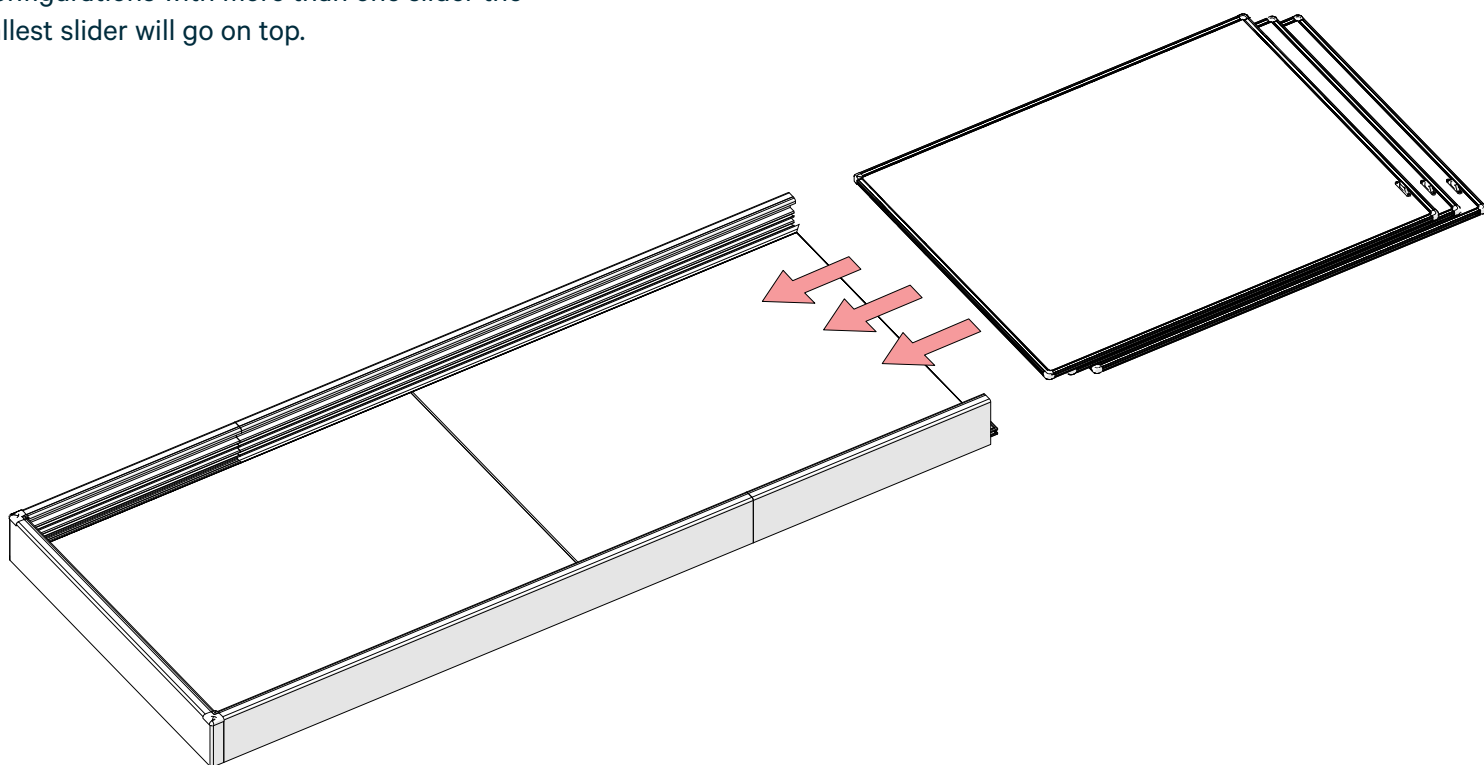

## Step 7

Install the second end cap.

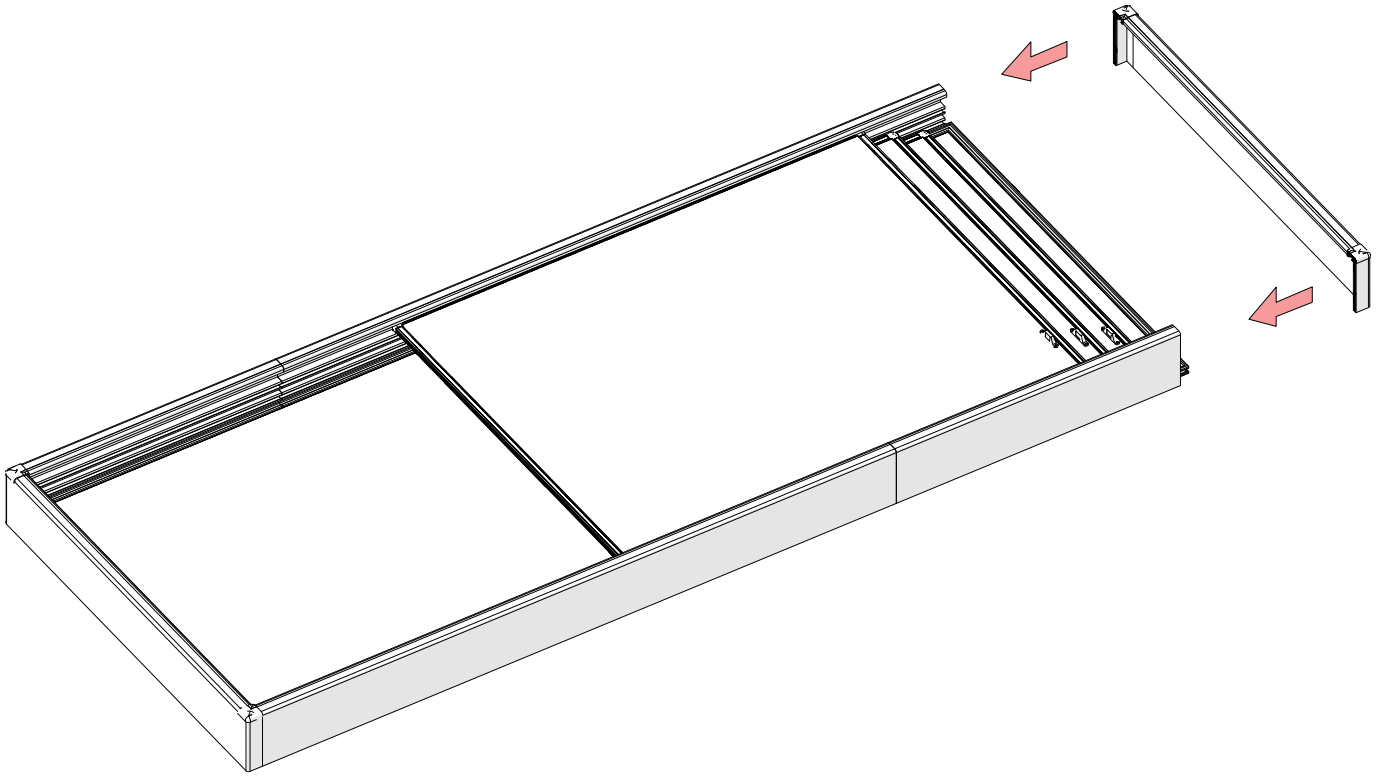

## Step 8

Flip the assembly over to install the corner brackets into the back. Be careful not to scratch the face of the markerboard.

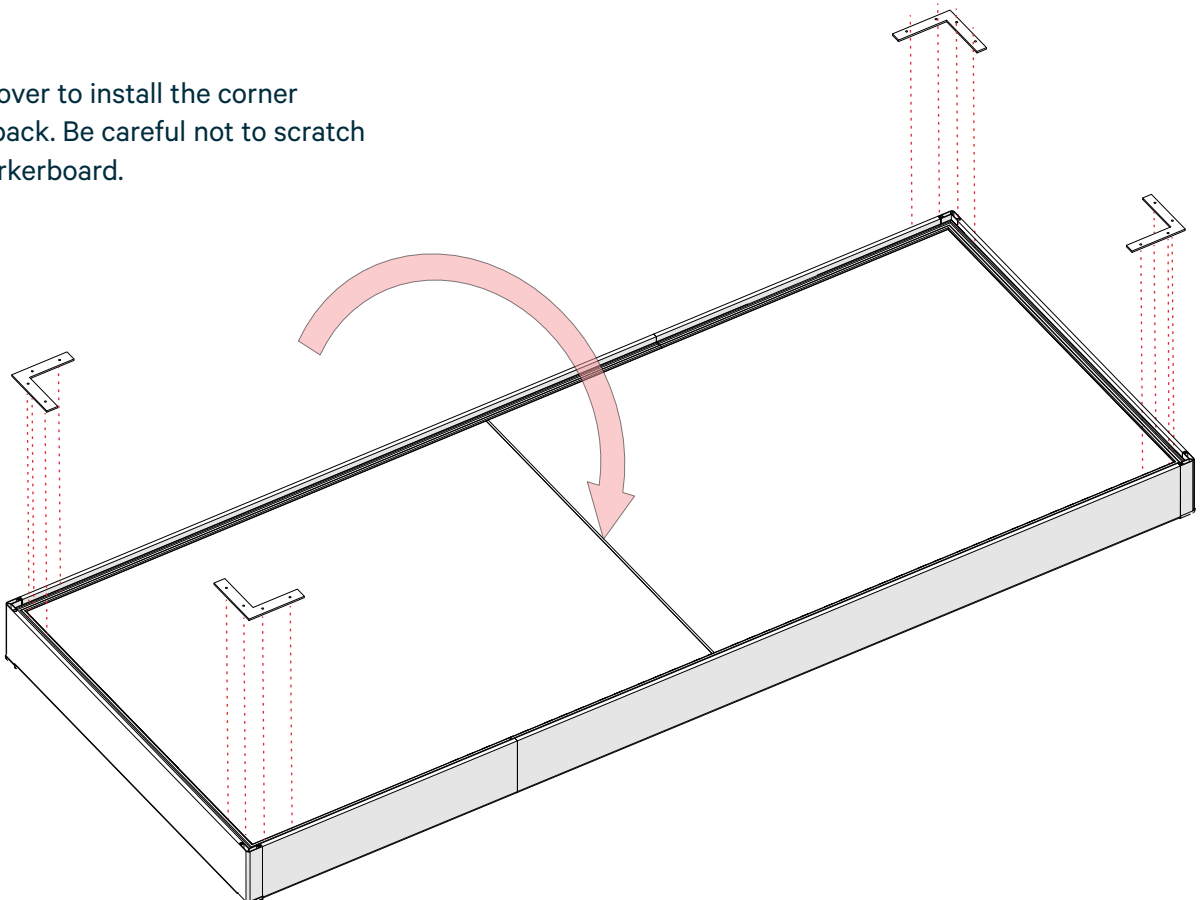

# Step 9

Mark two lines on the wall to match the full height of the markerboard assembly. Install “L” brackets into the wall.

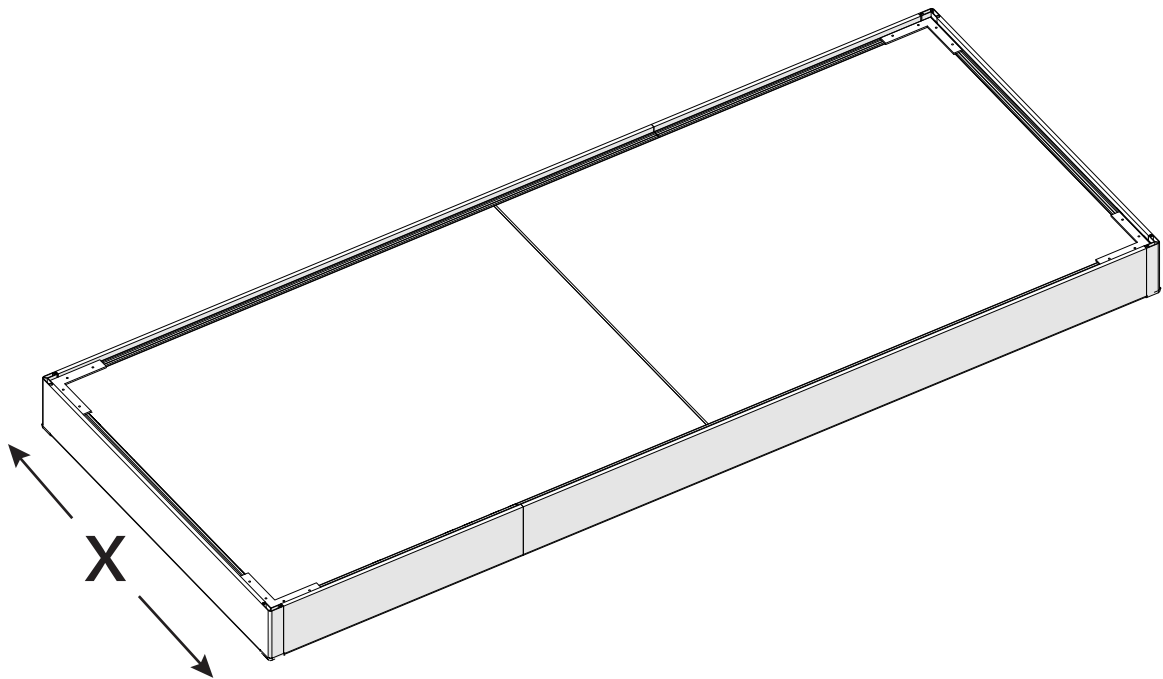
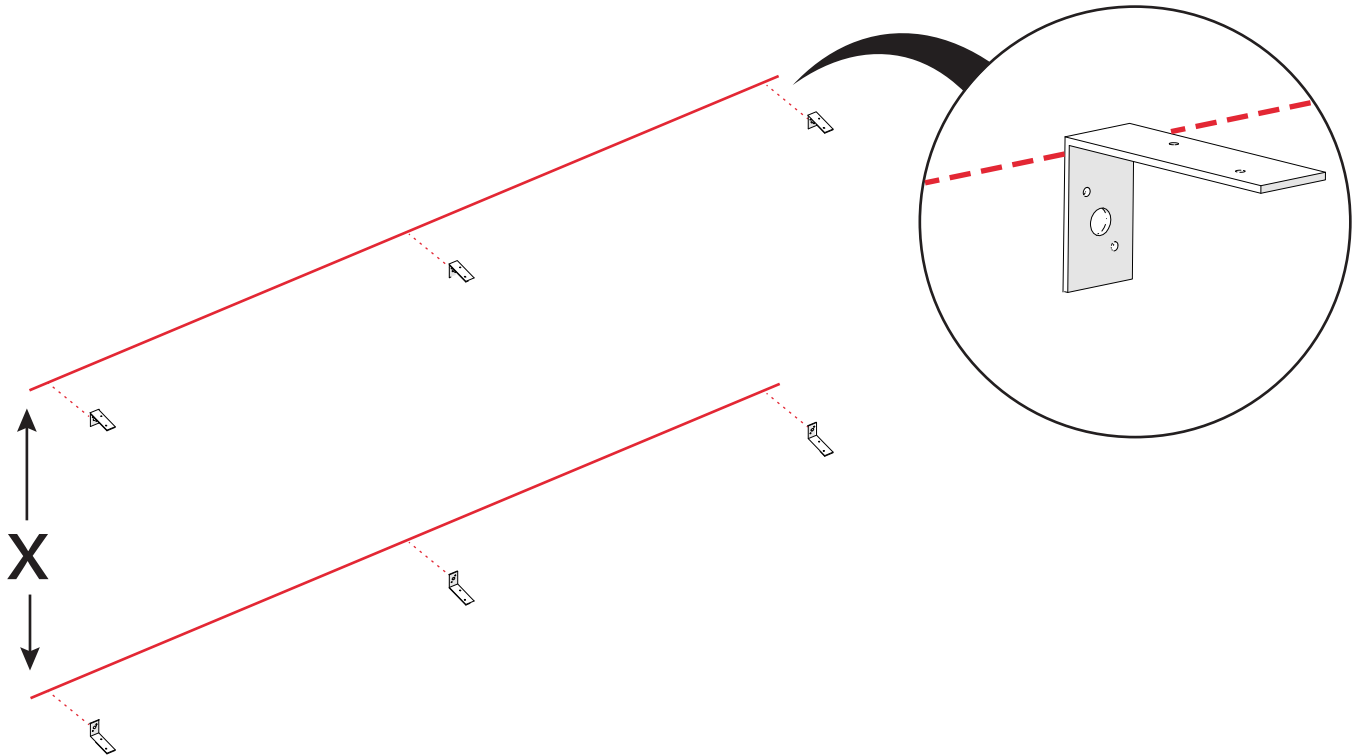

## Step 10

Carefully lift the markerboard assembly and set onto the brackets.

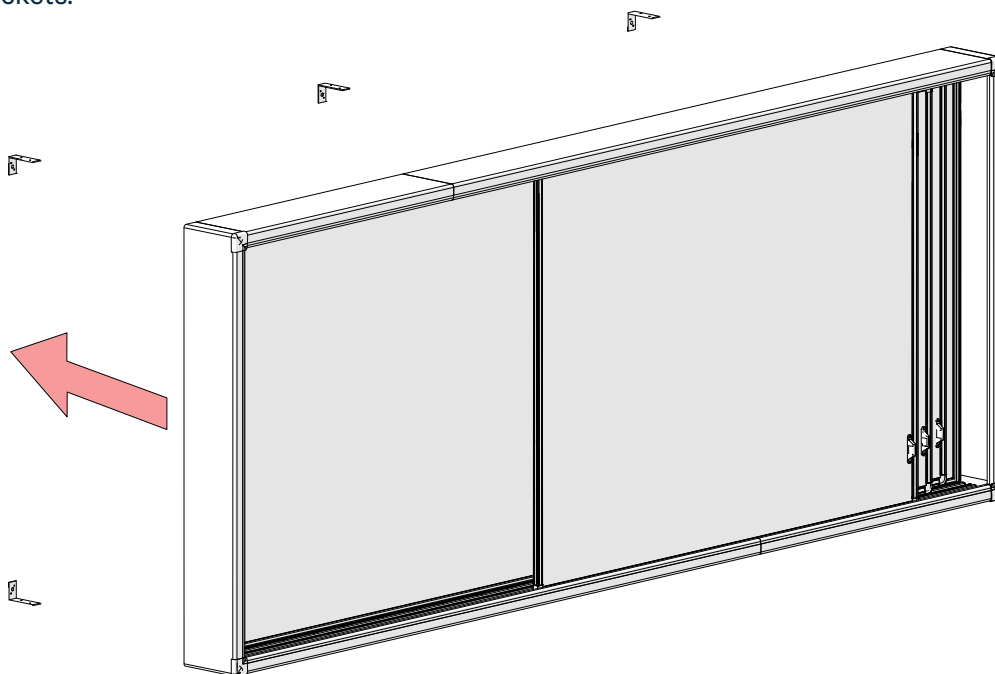

## Step 11

Fasten brackets to the frame to complete installation.

